



**SMART MOTOR DEVICES**  
*<http://www.steppmotor.biz>*

Stepper motor SM4247 with integrated driver SMD-1.6 mini

PASSPORT

SM4247/SMD.16.000

## 1. Product designation

This device is a stepper motor SM4247 with integrated control unit SMD-1.6 mini.

Stepper motor is intended for transformation of control signals in angular movement of the rotor with its fixation in the given position without feedback devices.

Integrated control unit SMD-1.6 mini is an electronic device mounted on the motor housing and is intended for this motor control.

## 2. Technical characteristics

### 2.1. Stepper motor SM4247 technical characteristics

Table 1

Motor phase current, Amp	1.68
Phase resistance, Ohm	1.65
Phase inductance, mH	2.8
Holding torque, kgf·cm <sup>1</sup>	4.4
Rotor inertia, g·cm <sup>2</sup>	68
Step angle, °	1.8
Max. radial force (20 mm from the flange), N	28
Max. axial force, N	10
Shaft radial play, no more, mm	0.02
Shaft axial play, no more, mm	0.08
Step angle accuracy	±5% from the whole step
Temperature Rise, °C	80
Average resource, hours	20000
Weight, kg	0.35
Number of leads	4

<sup>1</sup> Holding torque – the motor is powered but doesn't rotate

### Wiring diagram

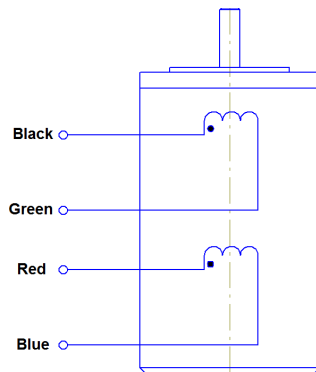

Img.1. Two phase stepper motor.

### 2.2. SMD-1.6 mini technical characteristics

The SMD-1.6 mini driver receives logic signals “Step”, “Direction” and “Enable” and convert them into motor commutation. The motor shaft moves one angle step (or micro-step) as the driver receives one “Step” signal. One step (or microstep) executes as the front edge of the voltage pulse on the “Step” input. Rotation direction depends on the voltage level and switches by changing voltage level on the “DIR” input. The motor can be urgent stopped by the active signal on the “EN” input.

### 8. Delivery in complete sets

SM4247 stepper motor with integrated control unit SMD-1.6 mini 1pcs.

Manual SM4247/SMD.16.000 1pcs.

### 9. Warranty

Any repair or modifications are performed by the manufacturer or an authorized company.

The manufacturer guarantees the failure-free operation of the controller for 12 months since date of sale when the operation conditions are satisfied – section 2.

The manufacturer sales department address: Smart Motor Devices OÜ,  
Tallinn Science Park Tehnopol, Mäealuse st. 4, Tallinn 12618, Estonia,  
Phone: + 372 6559914,  
e-mail: mail@stepmotor.biz  
url: <http://www.stepmotor.biz>

Date of sale:

Table 2

Output current per phase, Amp	1.6
Voltage input, VDC	12...48
High voltage level, VDC	5 - 24
<i>Please, connect current-limiting resistance when use high voltage more, than 5VDC: 1KOhm for 12VDC, 2KOhm for 24VDC.</i>	
Low voltage level, VDC	0...1
Logic signal current, mA	10...16
Minimum “Step” pulse length, $\mu$ s	3
Direction setting time, $\mu$ s	5

### 3. Dimensions of SM4247 stepper motor with integrated control unit SMD-1.6 mini

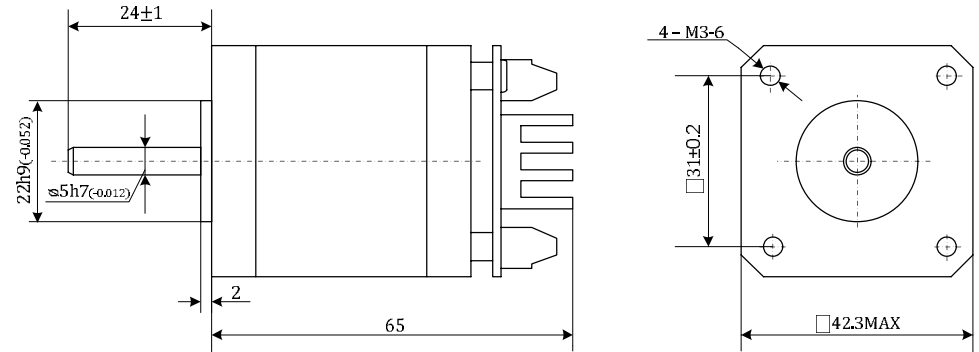

Img. 2. Dimensions of SM4247 stepper motor with integrated control unit SMD-16 mini without cover.

### 4. Construction of SMD-1.6 mini

SMD-1.6 mini is designed as a circuit plate with electronics elements, and radiator. Besides electronic components, there are indicating and control elements, connection terminals and connectors on the board:

- terminal screws for power supply, stepper motor and control circuit connection;
- LED for indication of the driver status – HL1;
- switches S1 и S2 to set microstepping mode.

### 5. Assembly and connection

Please, learn this manual carefully before connection and assembly.

Please wire just when power is off. Do not attempt to change wiring while the power is ON.

Please provide a reliable contact in connection terminals. During wiring, please, observe the polarity and wire management.

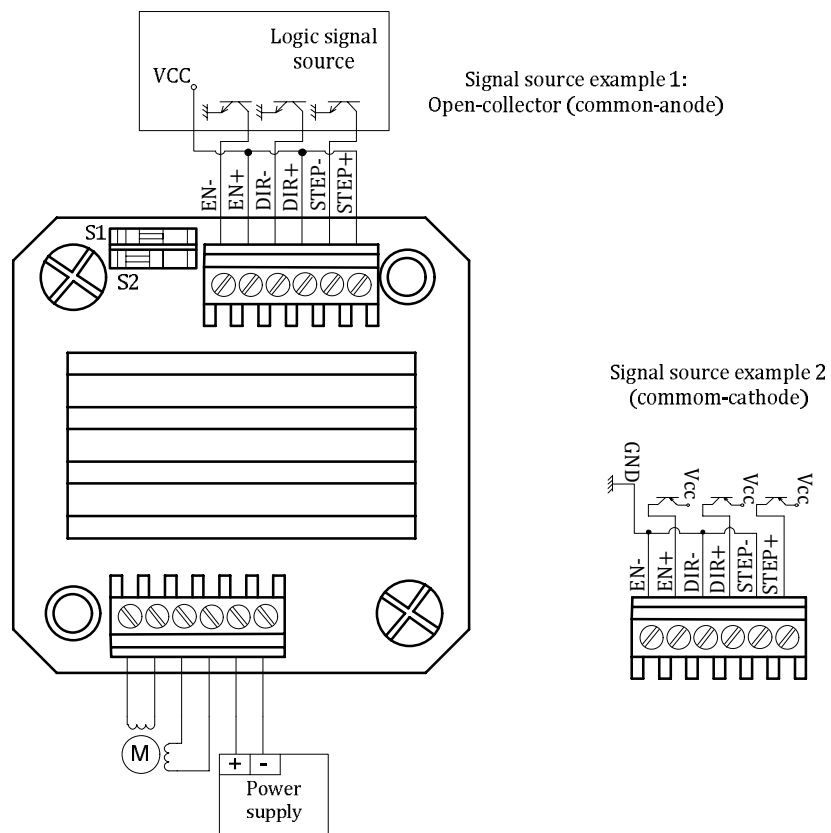

Img. 3. SMD-1.6 mini connection scheme.

Please, connect current-limiting resistance when use high level voltage more, than 5VDC: 1KOhm for 12VDC, 2KOhm for 24VDC.

### 6. Before starting

1. Make sure the power supply is turned off.
2. Make sure that stepper motor is connected to SMD-1.6 mini according img.1 and 3.
3. Connect STEP, DIR and EN inputs to the source of logic signals.
4. Chose suitable microstepping mode and set micro switches S1 and S2 according to the table 3.

Table 3

	1	1/4	1/8	1/16
S1	ON	OFF	ON	OFF
S2	ON	ON	OFF	OFF

7. Check wiring once again and turn on the power supply.
8. To control the stepper motor set the required sequence of logic signal “STEP”, “DIR”, “EN” according to the scheme – image 4. One step (or microstep) executes as the front

edge of the voltage pulse on the “STEP” input. Direction switches by changing voltage level on the “DIR” input. The motor windings as the front of the high voltage level on the “EN” input.

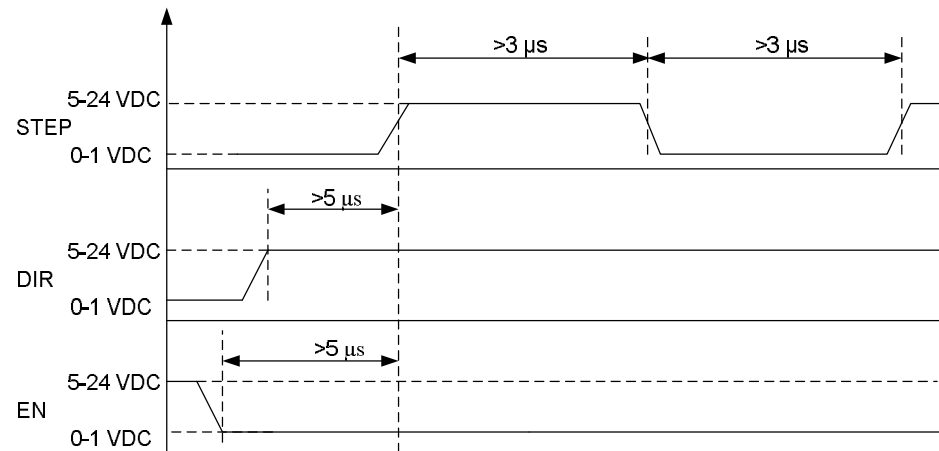

Img. 4. STEP, DIR, EN signals.

### 7. Operating conditions of SM4247 stepper motor and integrated control unit SMD-1.6 mini

Stepper motor is intended for continuous operating.  
Ambient temperature – (-25...+50)°C  
Humidity 90%  
Pressure (650...800) mm of mercury